

rous hydroxide may doubtless be ascribed to supersaturation phenomena. As the Fe^{++} ions are carried into the jelly by the electric current, a metastable supersaturated solution with respect to Turnbull's blue first forms. Ultimately precipitation occurs and the FeCy_6^{---} ions in the neighborhood are removed; the Fe^{++} ions then advance a few millimeters and form a new supersaturated solution, when the process is repeated. In the case of ferrous hydroxide, the OH^- ions form a supersaturated solution with the Fe^{++} ions. After precipitation has taken place, the OH^- ions must advance a few millimeters before a sufficient number of Fe^{++} ions are encountered to form a new supersaturated solution.

CHEMICAL LABORATORY, SWARTHMORE COLLEGE,
SWARTHMORE, PA.

[CONTRIBUTION FROM THE CHEMISTRY DEPARTMENT, OHIO STATE UNIVERSITY.]

THE SULFATE METHOD FOR STANDARDIZING A MAGNESIUM SALT SOLUTION.

BY C. W. FOULK AND O. R. SWEENEY.

Received September 1, 1914.

For a number of years one of us has had work in progress on the precipitation of magnesium as magnesium ammonium phosphate, the object being to discover, if possible, the causes of the discrepancies among the results by different methods and especially those obtained by various workers with the same method. As the investigation progressed it seemed to fall more and more into a study of the preparation of pure material and of the art of measuring the substances produced, until finally it narrowed to the question of preparing and standardizing a solution of a magnesium salt.

This trend of the work was an evolution rather than a part of the original program. At first a large amount of work was done in the way of comparing methods and of course different results were obtained. Different results were also obtained at times by the use of the same method. These differences were small and might have been due to impure reagents, improper handling or finally to lack of knowledge as to the exact concentration of the solution of magnesium salt used. As the subject was taken up by successive advanced students whose interest prompted them to undertake a share in the experimental work, new sources of error were found and studied. When these corrections were applied, they sometimes had the effect of reducing or eliminating the discrepancies in the results of the magnesium-ammonium-phosphate precipitations and sometimes they had the effect of making these discrepancies larger. The notes on the earlier part of this work were destroyed by the burning of the Chemical Building at the Ohio State University in 1904. A summary of the rest will be presented in a separate paper.

The lack of agreement in our results could, of course, be due to one, or to a combination of several causes, but the question of our knowledge of the content of the magnesium salt solution used seemed to be the most fundamental. Unless we could be absolutely sure of that, within our experimental errors, looking for other causes seemed a doubtful quest.

In the previous work the general plan had been to prepare pure magnesium chloride and then to standardize the solutions made from this pure chloride by treating a measured portion with a slight excess of sulfuric acid, evaporating and igniting the residue under carefully regulated conditions. This method appears to have the best standing in the literature, though it is not universally accepted.¹

It gave beautifully concordant results, it is true, but that meant only that it *might* be right. Other methods also gave concordant results, but they differed from the $MgSO_4$ values. Which was right, was the question we wanted answered and our preliminary problem was to find a way to do it. It is not easy to test a method of measurement unless a more accurate method is at hand and it at once became evident that we must look beyond the range of the usual analytical procedures to find such a method for the magnesium salt solutions.

In the preparation of the pure magnesium chloride, methods that had been used by atomic weight workers had been adapted, that is, we used the same purification processes but did not carry them quite so far. For example, recrystallizations were made only three or four times instead of nine or ten times. It seemed worth while, then, to see if more of the methods of atomic weight determinations might not be adapted to a problem of this sort.

Richards and Parker,² in the determination of the atomic weight of magnesium, had used anhydrous magnesium chloride as the starting point. This was sufficient to give that substance ample standing as an ultimate magnesium material if only the experimental difficulties of handling it could be overcome. It had the further advantage of being the very salt of which our standard solutions were composed, so that if we succeeded in preparing the chloride and in quantitatively transforming it into the sulfate it would be at least strong evidence of the correctness of the sulfate method of standardization. Accordingly, this was the plan of work finally adopted, the details of which will now be given.

Preparation of Material.

Distilled Water.—The distilled water of the Ohio laboratory is prepared by boiling the ordinary tap water by means of a steam coil and condensing the steam thus formed in block tin, the water then being stored in a tinned copper tank. The original tap water is softened by the city water works.

¹ Bube, *Z. anal. Chem.*, **49**, 535 (1910).

² *Z. anorg. Chem.*, **13**, 81 (1897).

with lime and soda ash and is then filtered through mechanical filters. This furnishes a high grade tap water containing little organic matter and carbon dioxide. The water used in this investigation was made by redistilling the ordinary distilled water from a Jena glass flask after the addition of a little sulfuric acid and of potassium permanganate. The condenser was block tin, a wad of glass wool being used to prevent the carrying over of spray from the boiling. Only the middle portions of the water were collected. It was received and stored in "Resistenz" glass bottles which had been steamed out.

Hydrochloric Acid.—This was prepared by dropping c. p. sulfuric acid into c. p. hydrochloric acid solution, sp. gr. 1.20, and receiving the evolved HCl in distilled water in a platinum dish which was set in a large glass vessel covered by a glass lid, provided with a tubulure for admitting the tube carrying the HCl gas. The evolution flask was arranged with a two-holed paraffin-soaked cork carrying a separatory funnel and the egress tube. No heat was applied.

Ammonium Hydroxide.—The so-called c. p. ammonium hydroxide solution (0.90 sp. gr.) was heated in a Jena flask and the NH_3 conducted through a Jena glass tube into water contained in a platinum dish which was protected from dust as described under the preparation of hydrochloric acid. A rubber stopper was used.

Ammonium Chloride.—Various attempts to purify ammonium chloride by sublimation proved unsuccessful and finally the scheme illustrated in Fig. 1 was used. Hydrochloric acid gas, generated in A, and NH_3 from B were passed into water in the platinum dish C till NH_4Cl began to crystallize out. The saturated solution was then analyzed, and the volume required in the preparation of the double chloride of ammonium and magnesium was calculated. This preparation left no residue on ignition.

Carbon Dioxide.—This was generated in a Kipp apparatus by the action of c. p. hydrochloric

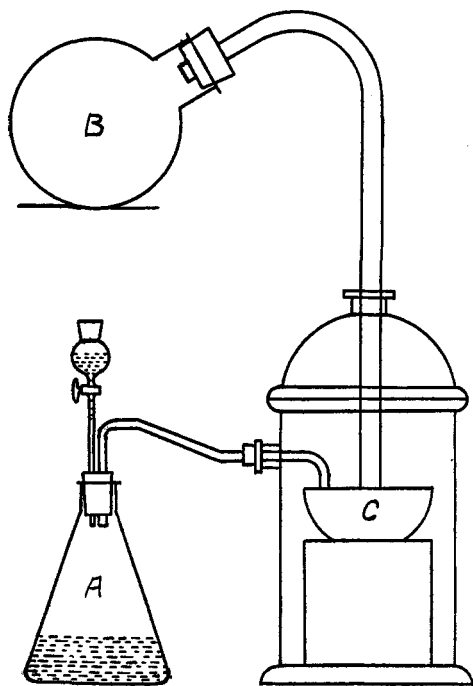

Fig. 1.

acid on marble. It was washed by passing it through KMnO_4 solution, water and sulfuric acid.

General Precautions and Tests of Purity.—All glass ware used was either of the Jena or Resistenz brand, and in all cases the vessels were steamed for an hour before using. In order to keep out dust, the reactions, if possible, were made to take place in covered vessels provided with tubulures for admitting the reagents. When this could not be managed, the substances were protected by dust shields or by watch glasses. Where the details of the method are not given below, it can be assumed that due precautions were taken. Ignitions were made with an alcohol lamp.

The different salts, acids, ammonia and water used were all tested with the spectroscope and if a sodium line showed they were rejected. Since all the materials originally contained a little sodium it was assumed that the purification had been carried far enough for our purposes when the sodium was eliminated.

Magnesium Salt.—The contents of an unopened bottle of c. p. $\text{MgCl}_2 \cdot 6\text{H}_2\text{O}$, containing 600 g. of the salt, were dissolved in 500 cc. of redistilled water. Apparently this was an unusually good specimen of the salt. Treatment with H_2S and a little NH_4OH produced no precipitate and also no test for calcium could be found with $(\text{NH}_4)_2\text{C}_2\text{O}_4$. Duplicate tests were made on portions of the solution to which very small quantities of the heavy metals and of calcium had been added and these portions at once gave positive tests with H_2S and with $(\text{NH}_4)_2\text{C}_2\text{O}_4$. The spectroscope, however, showed the presence of sodium. To effect the separation from this metal, precipitation of the magnesium as the double carbonate of magnesium and ammonium was employed.¹

A number of experiments were first made to determine the best conditions for precipitation and finally the following was adopted: About 25 cc. of the concentrated magnesium chloride solution were placed in the platinum dish A, Fig. 2, and diluted till the dish was nearly full. Ammonia produced in the still B, and carbon dioxide, made and washed as described above, were now led into the solution as shown in the figure. Cold water was kept circulating around the dish by means of the tubes shown at H. Both the NH_3 and CO_2 were passed into the solution for two hours when the NH_3 was stopped and the current of CO_2 allowed to continue for twenty minutes more. This caused the precipitate to take on a crystalline form, that made it easy to handle. The dish was finally removed from its container and the salt washed 40 to 50 times by decantation. The precipitate was then transferred to a platinum funnel, containing a finely perforated platinum cone, on which it was washed for about four hours, after which it was transferred to a platinum dish, covered with a watch glass, and heated in a hot air oven till no more odor

¹ Bray, THIS JOURNAL, 31, 611 (1909).

of ammonia could be noted. The salt so obtained was labeled Preparation I.

The spectroscope showed no sodium, and quantitative tests for calcium and platinum gave negative results. This procedure of treating 25 cc. portions of the original magnesium chloride solution was repeated until a sufficient amount of Preparation I was obtained.

Preparation II was next made by dissolving portions of No. I in HCl, in the large platinum dish in the apparatus used before, and precipitating and washing as described above for Preparation I. This salt was also tested spectroscopically and showed no sodium.

Double Chloride of Ammonium and Magnesium.—A suitable amount of Preparation II was placed in a large platinum dish, covered with water

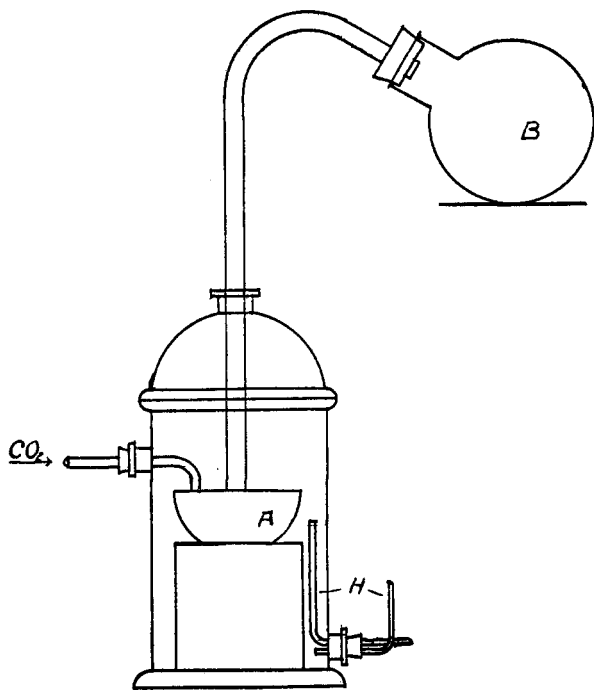

Fig. 2.

and hydrochloric acid gas passed in till the salt was dissolved. Ammonium chloride in slight excess of the amount to make $\text{MgCl-NH}_4\text{Cl}$ was then added. (The approximate amount of magnesium in Preparation II had been determined.) The mixture in the dish was evaporated just to dryness over an alcohol lamp, after which the resulting mass was dissolved in water and crystallized. The first crop of crystals was again dissolved and recrystallized. The product so obtained was preserved and marked

Preparation III. All reagents used in preparing it were the pure ones described above and all the operations were carried out in platinum. The greatest precautions against dust were also observed.

A number of portions were discarded, because, during the evaporations, a scum gathered on the surface of the solution. The nature of this scum was not learned, further than that it was completely volatile.

Apparatus for the Preparation of Anhydrous Magnesium Chloride and its Conversion into Magnesium Sulfate.

Magnesium ammonium chloride, when heated in a current of dry hydrochloric acid gas, loses water and ammonium chloride and leaves a residue of magnesium chloride which can be fused in order to free it from the last traces of volatile matter. The anhydrous magnesium chloride is, however, so hygroscopic that it must, at all times, be protected from the least trace of moisture. Richards and Parker,¹ in their determination of the ratio $2Ag : MgCl_2$, used the well-known Richards apparatus, which permitted the bottling of the boat containing the magnesium chloride before it was exposed to the air of the laboratory. Such an apparatus with its specially ground glass connections was, however, not available for us and we therefore were obliged to find a substitute, the details of which can be seen from Fig. 3. It is perhaps needless to say that this

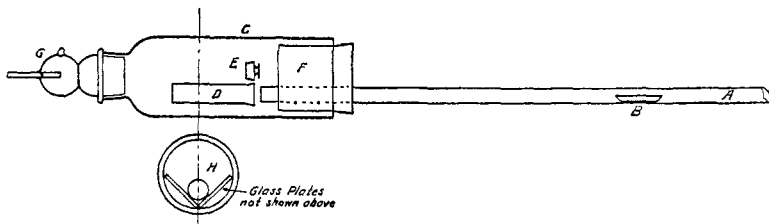

Fig. 3.

apparatus, crude as it may be, was the result of much experimenting before a workable combination was obtained. Its operation was as follows:

The hollow, ground-glass stopper G was removed and the platinum boat containing a portion of the double chloride was pushed into place in the combustion tube A, which was supported in a long combustion furnace. The weighing bottle D and its stopper E were next put into the bottling chamber C, which was then closed by the stopper G. Dry HCl was next passed into the apparatus through the tube sealed into the stopper G, the combustion tube was heated to the requisite temperature, the HCl was displaced by dry air and when the whole had cooled down to the temperature of the laboratory, the boat was pushed back into the weighing bottle by means of a long glass rod operated from the other end of the combustion tube. The stopper was likewise pushed into the weighing bottle, after which the bottling chamber was opened by removing G and the weighing bottle taken out to the balance.

In the construction of this apparatus the difficulty that seemed hardest to overcome was the matter of the connection between the combustion tube and the bottling chamber. In the Richards apparatus, which was our model, this was effected by a ground-glass joint. It served the

¹ *Loc. cit.*

two necessary purposes of giving a tight connection and yet making disconnecting easy for inserting the weighing bottle. We had, however, no means for grinding such joints and therefore had to meet the situation in some other way. Experiments showed that dry HCl acted upon rubber stoppers, but appeared to have no effect upon paraffin. A paraffined cork therefore suggested itself. The two important objections, the low melting point of paraffin and the nuisance of melting in the joint for each determination, were overcome (1), by using a very long combustion tube so that the joint did not come near the furnace, and (2), by having the opening into the bottling chamber at the other end.

This permitted the use of any suitable piece of stock apparatus already provided with a ground stopper carrying a sealed-in tube for connection with the HCl generator and air supply. Such a stock piece was found in the ordinary gas washing bottle. One about 24 cm. long and 6 cm. in diameter was taken, the bottom was cut off for the insertion of the cork with the combustion tube and one of the tubes through the stopper was closed, the other serving for the connection with the drying train. This made an excellent bottling chamber and permitted a permanent connection with the combustion tube. This was accomplished by using a cylindrical cork F, so that it could be inserted its full length into the bottling chamber. This cork, after being bored, was dipped into melted paraffin, the combustion tube was then inserted and the cork pushed into place. The apparatus was then supported in an upright position and melted paraffin was poured through a funnel onto the cork till a thick layer was produced, the end of the combustion tube being left almost flush to avoid the pocketing of gas behind it. This gave a strong joint that withstood perfectly the handling it received. Owing to the length of the combustion tube and protection shields of asbestos board, not the least softening occurred. It was not called upon to withstand pressure and consequently remained tight. The most careful watching failed to show any action of the HCl gas upon the paraffin or any penetration of the gas to the cork under the paraffin.

The handling of the stopper of the weighing bottle was facilitated by the construction of a trough from two narrow glass plates in the bottom of the bottling chamber, a cross-section of which is shown at H. The cork F had an eccentric boring so that the end of the combustion tube came opposite the opening of the weighing bottle as it lay in the trough. The bottling chamber was long enough so that, after the boat had been pushed into the weighing bottle by means of a long rod inserted from the other end, the bottle itself could be pushed back a little to allow the stopper previously placed on it to fall down in front of the mouth, from which position it was easily pushed into place and could be tightened by light blows with the end of the rod.

The apparatus for generating and drying the HCl gas and for drying the air is illustrated in Fig. 4. A, A, A, A are gas washing bottles. These were half filled with concentrated sulfuric acid. The bottle B was of

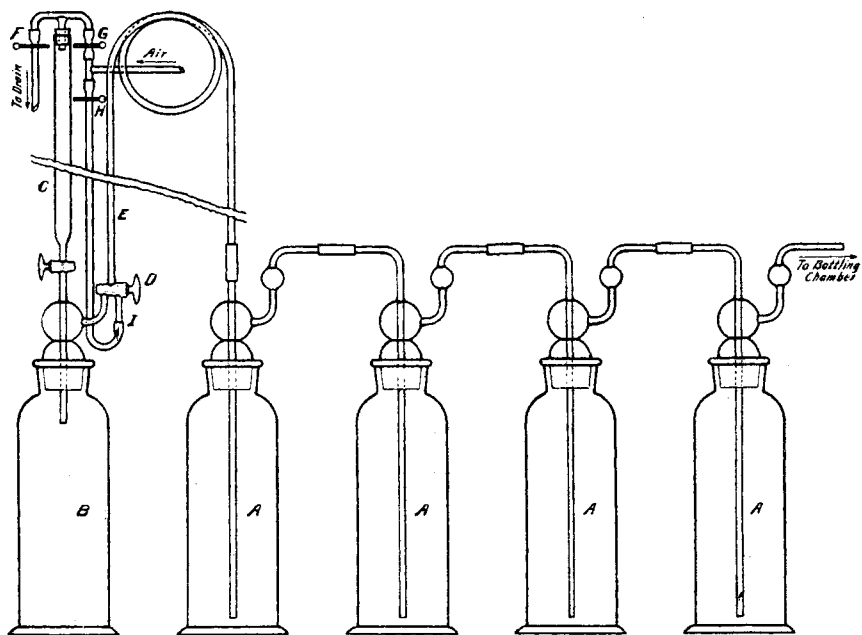

Fig. 4.

the same size and design. The large tube C and the two-way cock D and tube E were sealed to the tubes through the stopper. Hydrochloric acid gas was generated by dropping concentrated sulfuric acid from the buret C into concentrated hydrochloric acid solution in B.

On first trying this apparatus it was found that the back pressure was so strong that the HCl gas was forced up through the column of H_2SO_4 in the buret. To prevent this, the arrangement of T-tubes and rubber tubing, as shown in the drawing, was put on. This was connected to the air supply of the laboratory, the pressure of which, for our purposes, was regulated by inserting a T-tube dipping into a mercury well as shown in Fig. 5. The supply of air was kept at such a point that a slow stream of bubbles constantly escaped through the mercury. By closing F and setting the two-way cock D so that an opening from B to A was provided, and leaving G open, an air pressure of any desired amount, as controlled by the regulator above, could be maintained over the acid in C. When

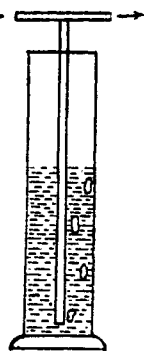

Fig. 5.

the stream of hydrochloric acid was to be replaced by air, the two-way cock was turned so as to disconnect B and connect the tube E with the tube I. By closing G and opening H a current of air could be sent through the washing bottles. By opening F any HCl gas still coming from B could escape through C to the drain.

The washing bottles themselves were connected by joints made from Kotinsky's cement, as shown in Fig. 6. A and B are the glass outlet

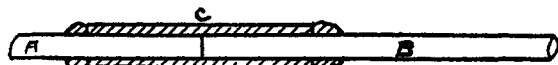

Fig. 6.

and inlet tubes, respectively, of two bottles. C is a short piece of glass tubing, large enough to slip loosely over the other two. The space between was filled with the Kotinsky cement.¹ This arrangement made a very strong and satisfactory joint.

The suction and absorption flask illustrated in Fig. 7 was employed for disposing of the fumes from the treatment of the double chloride and it also served, it is believed, to prevent a back current of laboratory air into the main apparatus. The tube A fitted loosely over the end of the combustion tube, so that when suction was applied at B a steady current of air flowed through the space between the two tubes carrying the ammonium chloride and hydrochloric acid into the sodium hydroxide solution. This arrangement was preferred to a direct connection with the combustion tube, because it did not produce

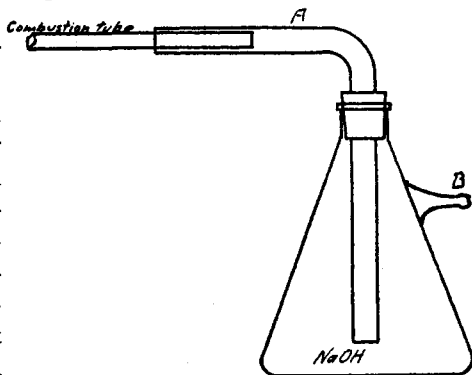

Fig. 7.

reduced pressure in the apparatus with consequent danger of moist air leaking in and because it was easily handled and did not clog with solid ammonium chloride. As a final point in the construction of the apparatus it should be mentioned that the ground-glass joint of the bottling chamber and the two glass cocks on the HCl generator were lubricated with syrupy phosphoric acid.

Weights and Balance.—The weights used were gold plated, from Sartorius. They had been calibrated by the Bureau of Standards and were marked N-5543. The balance was a long arm Troemner. Dishes of sulfuric acid were kept inside the case.

Method of Weighing.—All weighings were made by the method of tarés. The magnesium chloride and the magnesium sulfate, excepting

¹ THIS JOURNAL, 30, 13 (1908).

where the crucible method (see below) was used, were in a platinum boat which was contained in a glass-stoppered weighing bottle. Another bottle of similar size and shape was tared against this one in such a way that it was a trifle lighter than the first one plus the empty platinum boat.

In the crucible method for the conversion of the chloride into the sulfate the same method of weighing was used. The crucible containing the sulfate was put into a short, wide-mouthed weighing bottle, which was counterpoised by another one of the same size and shape carrying an empty crucible.

In all cases after removing the weighing bottle from the combustion apparatus it was placed, together with its tare, in a desiccator over sulfuric acid and left for several hours. On being taken out for weighing, the glass pieces were wiped with a dry cloth and left on the balance for about an hour. When the empty boat was weighed, it was first heated to glowing and placed at the side of its weighing bottle in the desiccator to cool. When cool the desiccator was opened, the boat put into the bottle and the stopper inserted. This operation required only a few seconds. A similar procedure was employed in obtaining the weight of the empty crucible for the sulfate method.

Typical Operations.

(1) *Conversion of the Double Chloride into Anhydrous Chloride.*—The platinum boat, previously weighed, was filled with Preparation III and placed in the combustion tube about three-fourths of the length of the tube distant from the bottling chamber. The weighing tube with its stopper was next placed in position in the bottling chamber which was then closed. The absorption apparatus at the other end of the tube was now put into place and the suction started. A current of dry HCl was passed through the apparatus and continued till all the air was displaced, when two low flames were started at a distance from the boat so that the current of HCl was warmed. This was continued until the water was driven out of the salt, a point easily recognized by experience. More burners were then lighted in such a series that the heat was very gradually increased. When the ammonium chloride was all expelled, burners were lighted along the full length of the tube so as to obtain the maximum temperature around the boat for the purpose of fusing the $MgCl_2$. Occasionally an extra Bunsen burner was necessary to accomplish this. The chloride was kept in a molten state for about ten minutes, after which it was gradually cooled by turning off a few burners at a time. When cool, the current of HCl was replaced by one of dry air, which was continued till all of the HCl was driven out. The absorption apparatus was then removed and the boat pushed back into the weighing tube by means of a long rod. The stopper was next pushed into place

and tapped fast. The current of air was then shut off and the bottling chamber opened for removing the weighing tube.

(2) *Conversion of the Chloride into the Sulfate.*—Two methods were employed which may be designated as (a), the boat method, and (b), the crucible method.

(a) *The Boat Method.*—The anhydrous magnesium chloride in the boat was covered with dilute sulfuric acid containing 0.16 g. H_2SO_4 per cubic centimeter. The excess of water was evaporated on a steam plate—a cast iron box through which live steam circulated—in an apparatus as shown in Fig. 8.

The boat B was placed in a large glass tube A which was laid on the steam box C. A current of air, washed with sulfuric acid and filtered through a wad of glass wool, was passed through the tube A to

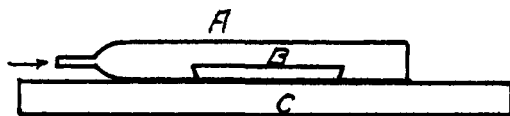

Fig. 8.

hasten the evaporation and also to protect the contents of the boat from dust. When the bulk of the water had been removed in this way the

boat was placed in the combustion apparatus, the excess of H_2SO_4 driven off and the resulting MgSO_4 ignited to constant weight at a low red heat. It was then bottled and weighed as described above for MgCl_2 .

Trouble was at first experienced during the evaporation of the dilute acid by a tendency of the magnesium sulfate to creep over the sides of the boat. This was remedied by smearing the edges with a trace of vaseline. Blanks were run to prove that no residue was left by the vaseline.

(b) *The Crucible Method.*—This consisted in dissolving the chloride and transferring it to a platinum crucible before transforming it into the sulfate. The method was used merely because it more nearly resembled the conditions that would obtain in the actual standardization of a magnesium chloride solution. By way of preparation for this method, the end of the combustion tube was raised slightly while the chloride was in a molten state, thus causing it to collect in one end of the boat, where it was allowed to solidify. Melted magnesium chloride does not wet platinum; consequently, this operation was very successful. The transfer to the crucible was made by putting the end of the boat containing the chloride into the crucible, where it was covered with a little dilute sulfuric acid. After solution was complete the boat was rinsed off, dried and examined for traces of salt that might remain. This manipulation seems more difficult than it really was, for it was possible to remove all the chloride from the boat without filling the 30 cc. crucible more than half full.

The excess of water was driven off by heating on the steam box under the protection of an inverted funnel, the bell of which had upturned edges for collecting the condensation. A current of air, filtered and washed

as described above, was passed through the funnel during the evaporation. The excess of acid was driven off by heating in a small porcelain drying oven. The final ignition of the sulfate was made by setting the crucible on a small platinum triangle in a larger crucible also of platinum. The outer crucible was heated so that the temperature between the two was 700° , as measured by a Hoskin's pyrometer. The crucible containing the sulfate was cooled in a desiccator over sulfuric acid and when cool was set into a wide-mouthed weighing bottle closed with a ground-glass stopper. Ignitions were always made to constant weight and on two occasions the treatment with sulfuric acid was repeated.

Two or three complete operations were at first carried through to become familiar with the manipulation and then the following, using Preparation III, were made: The calculated values in Column 3 were obtained by multiplying the weights in Column 1 by 1.26407. In deriving this factor the atomic weights in the 1914 table were used. Weighings were not corrected to vacuum since the difference in the specific gravities of the two substances— MgCl_2 2.18, and MgSO_4 2.66—is so small that the error introduced by disregarding it is negligible in comparison with the errors as given in Column 4. The letters *b* and *c* in Column 1 indicate the boat method and crucible method of transforming the chloride into the sulfate.

MgCl_2 taken.	MgSO_4 obt.	MgSO_4 cal.	Error.
0.7530 <i>b</i>	0.9520	0.9518	+0.0002
0.1374 <i>b</i>	0.1733	0.1737	-0.0004
0.4027 <i>c</i>	0.5094	0.5090	+0.0004
0.5312 <i>c</i>	0.6714	0.6715	-0.0001
0.6957 <i>b</i>	0.8794	0.8794	0.0000
0.5457 <i>c</i>	0.6900	0.6898	+0.0002

In all, 3.0657 g. of MgCl_2 were transformed into MgSO_4 , giving 3.8755 g. The calculated amount is 3.8753 g.

Discussion.

Of the six experiments carried through, four gave good results and two, the second and third, have rather large errors. We have no explanation to offer for these, since there was nothing observed in their carrying out to suggest that they were different from the others. It is to be noted that one is by the boat method and one by the crucible method and that one carries a minus and one a plus error. Indeed the plus and minus errors are so distributed in the whole series that they may fairly be ascribed to manipulation rather than to impure materials or to some inherent source of trouble in the nature of the reaction.

We regret greatly that time did not permit carrying through at least twice as many experiments but, as it is, we believe that the results add materially to the evidence in favor of the correctness of the sulfate method for standardizing a magnesium salt solution.

After all, though, if work of this type has any value it is not so likely to lie in the actual results obtained by the first attempt as in the general suggestion it offers for such studies of the more important analytical reactions. It is at any rate the intention in this laboratory to carry out other investigations of a similar kind.

Summary.

In this article there has been described:

1. The preparation of pure magnesium salt for use as a standard in analytical work.
2. An easily constructed piece of apparatus by which material can be heated in a combustion tube and transferred to a weighing bottle without exposure to the air.
3. A set of experiments in which anhydrous magnesium chloride was transformed into magnesium sulfate.

COLUMBUS, O.

BEHAVIOR OF AMMONIUM PHOSPHOMOLYBDATE WITH AMMONIUM HYDROXIDE.

By PULIN BIHARI SIRCAR.

Received September 15, 1914.

In the Woy¹ method of estimation of phosphates, the phosphoric acid is first precipitated as ammonium phosphomolybdate, which is then dissolved in ammonia and reprecipitated by magnesia mixture. Evidently, in solution, free phosphate ions exist.

Gibbs² has made a thorough investigation of these reactions and he has shown that the ammonium phosphomolybdate dissolves in ammonia and on allowing the ammoniacal solution to stand, glistening needles or prisms, having the composition $2(\text{NH}_4)_3\text{PO}_4 \cdot 5\text{MoO}_3 \cdot 7\text{H}_2\text{O}$ separate out. The present investigation was undertaken for a fuller study of the solubility of ammonium phosphomolybdate in ammonium hydroxide. A pure sample of ammonium phosphomolybdate was prepared by precipitating a solution of sodium-hydrogen phosphate with ammonium molybdate. The precipitate was then washed free from mother liquor and dried. The dry yellow powder was placed in a beaker and an excess of strong solution of ammonia was added to it and stirred; a white crystalline salt was at once thrown down with evolution of heat.

This white substance was immediately dried by pressing between the folds of bibulous drying paper and analyzed. The substance was not put in a desiccator but dried in air.

Calc. for $(\text{NH}_4)_2\text{Mo}_2\text{O}_7 \cdot 3\text{NH}_3$: Mo = 49.11; N = 17.88; H = 4.42; found: Mo = 49.8; N (by Kjeldahl) = 17.25; H (by combustion) = 4.15.

¹ *Chem. Ztg.*, 21, 442.

² *Am. Chem. J.*, 5, 361, 391, etc.